

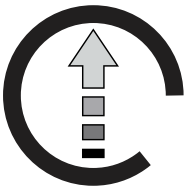

**Swivel Castors**



**Height Adjustable**

Seat Height 410 - 550mm



**Tool Tray Holder**

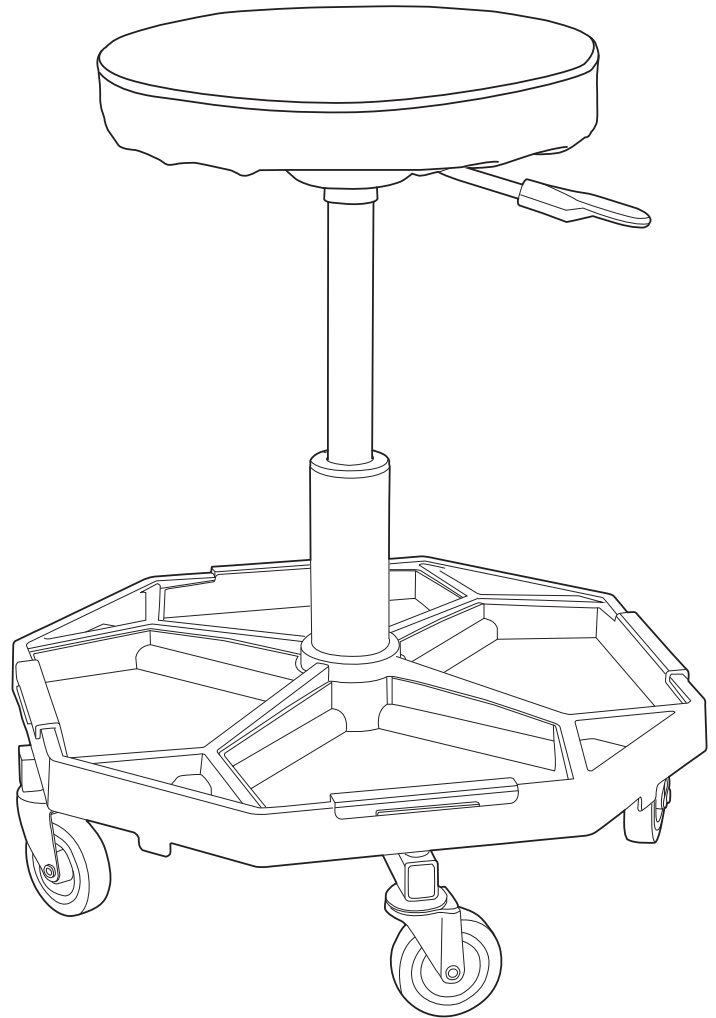

**150  
kg**  
CAPACITY

Edition : 1.0  
Date: (11/25)

## Instruction Manual

# MECHANIC'S ROLLER SEAT MRS-550

Order Code: (A3605)

## BEFORE ASSEMBLING

Please read this instruction manual before assembly.



### CAUTION

Before assembly please pay attention to the following points in priority;

**Confirmation of components:** Before assembling, please confirm all parts arrived and are in good order.

**Site for assembly:** Please assemble it on the soft floor such as smooth carpet and flannel blanket. When you assemble on wooden floor, please put thin towels on the floor.

**Points for attention when assembling:** Please wear gloves to ensure that it can be assembled safely, and use two persons to help in the assembly process.

## SAFETY INFORMATION

1. Do not ride on this seat or use to swivel out of control. Always use as its intended purpose.
2. Engage both brakes when this seat is not being moved. This prevents it rolling away.
3. Do not tow this seat with power equipment.
4. Always use this seat on a flat, level, hard surface. Do not use on an inclined surface as serious injury can occur.



**CAUTION:** Do not attach or mount this product to a vehicle. This may cause personal injury or product damage. Mounting this product to any vehicle in any manner will void warranty.



**CAUTION:** Keep the seat on level surfaces. The product may become unstable and tip if stored or moved on an un-level surface, which may cause personal injury or product damage.



**CAUTION:** Do not stand on this product. You may fall which may cause personal injury or product damage.



**CAUTION:** Lock the caster wheel brakes to stop the seat rolling away or serious injury can occur.



**CAUTION:** Note the weight of the person and never overload its working capacity.



**CAUTION:** Use safety shoes as all times.



## WARNING!

**WARNING! READ, UNDERSTAND AND FOLLOW ALL INSTRUCTIONS, AND WARNINGS BEFORE OPERATING THIS TOOL. FAILURE TO DO SO MAY RESULT IN PERSONAL INJURY AND/OR PROPERTY DAMAGE AND WILL VOID WARRANTY.**

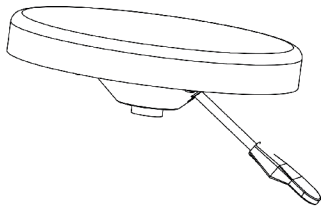

① Foam-Padded Seat

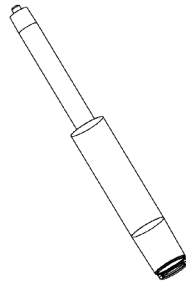

② Pneumatic Cylinder

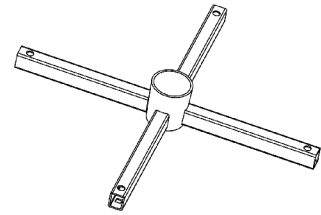

③ Bottom Cross

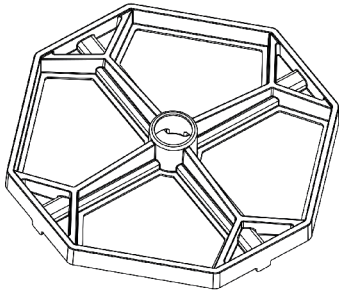

④ Base Plate

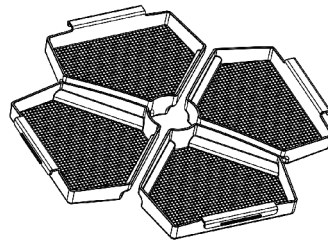

⑤ Removable Plastic Chassis

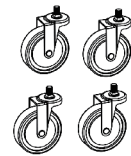

⑥ 2.5" Casters



⑦ Tube Type Nuts

Part No.	Description	Qty
1	Foam-Padded Seat	1
2	Pneumatic Cylinder	1
3	Bottom Cross	1
4	Base Plate	1
5	Removable Plastic Chassis	4
6	2.5" Casters	4
7	Tube Type Nut	4

## STEP 1.

Attach the four 2.5" casters (6) to the bottom cross frame (3). Secure each caster using a tube-type nut (7) and tighten firmly, as shown in the figure.

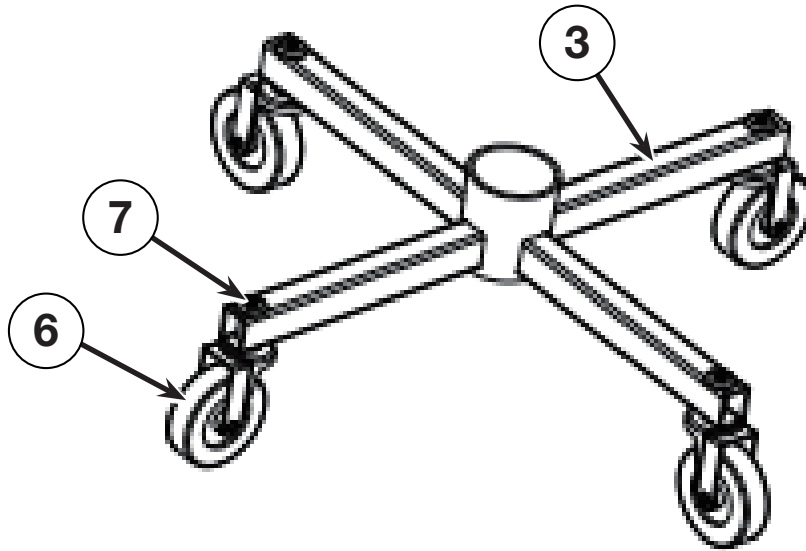

## STEP 2.

Position the base plate (4) onto the bottom cross frame (3). Ensure it is properly aligned and fully seated, as shown in the figure.

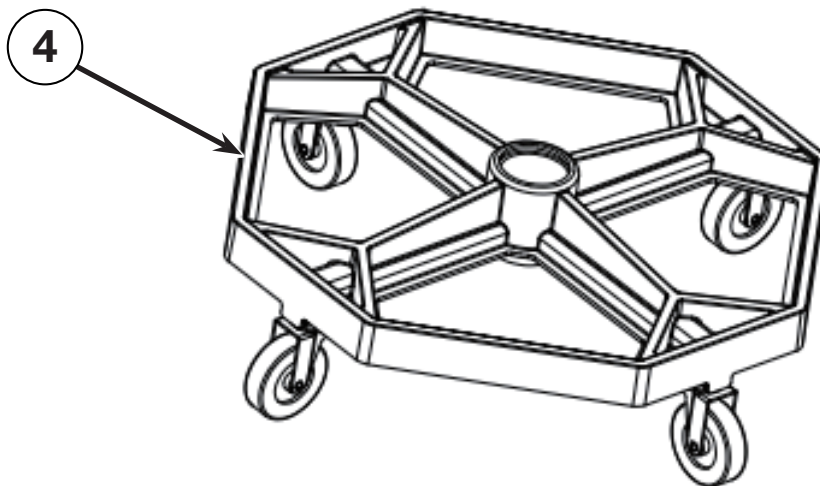

### STEP 3.

Insert the four removable plastic chassis (5) into the base plate (4), ensuring each piece is positioned securely, as shown in the figure.

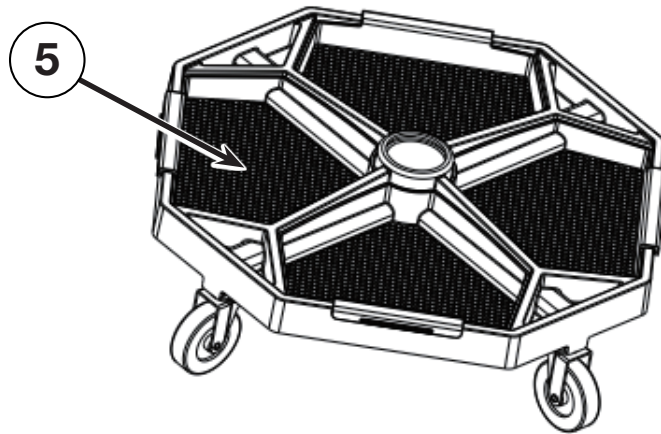

### STEP 4.

Insert the pneumatic cylinder (2) into the bottom Cross Frame (3), ensuring it is fully seated and aligned, as shown in the figure. Then, remove the protective cover from the top of the cylinder.

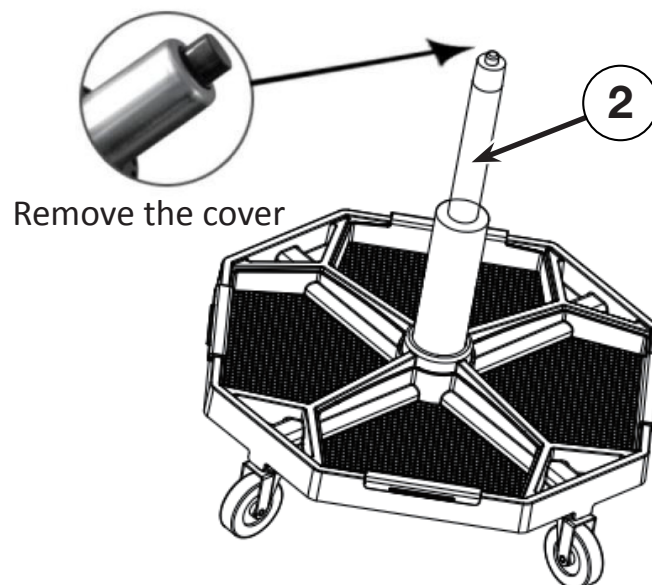

**STEP 5.**

Place the foam-padded seat (1) onto the small end of the pneumatic cylinder (2), ensuring it is securely seated. Your mechanics seat is now fully assembled and ready for use.

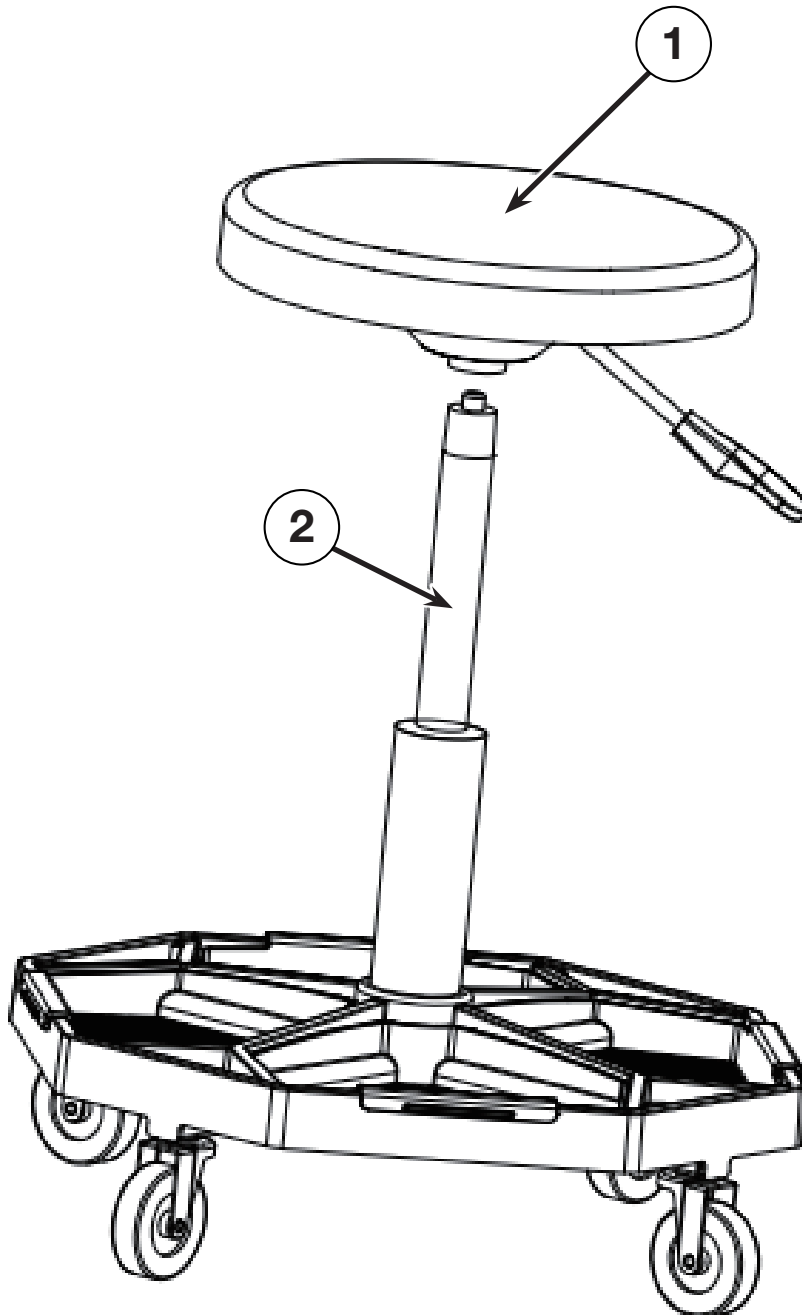





#### **ENVIRONMENT PROTECTION**

Recycle unwanted materials instead of disposing of them as waste. All tools, accessories and packaging should be sorted, taken to a recycling centre and disposed of in a manner which is compatible with the environment. When the product becomes completely unserviceable and requires disposal, drain any fluids (if applicable) into approved containers and dispose of the product and fluids according to local regulations.

IMPORTED BY

---

**HARE & FORBES**  
**MACHINERYHOUSE**

Australian Distributor

**Hare & Forbes**  
**Machineryhouse**  
Sydney - Melbourne  
Adelaide - Brisbane - Perth

**Ph: 1300 202 200**  
**[www.machineryhouse.com.au](http://www.machineryhouse.com.au)**

**MACHINERYHOUSE**

New Zealand Distributor

**Machineryhouse**  
Auckland  
Christchurch

**Ph: 0800 142 326**  
**[www.machineryhouse.co.nz](http://www.machineryhouse.co.nz)**